

PRODUCT NAME .....

## 18 V Cordless Impact Driver Drill\*1

Models DV 18DD, DV 18DDX\*2

D

\*1: "Cordless Combi Drill" for Europe

\*2: Designed for operating in UK only

### CONTENTS

Page

|   |   |
|---|---|
| REPAIR GUIDE .....  | 1 |
| 1. Precautions on disassembly and reassembly .....                | 1 |
| • Disassembly .....   | 1 |
| • Reassembly .....  | 2 |
| • Checking after reassembly .....                                 | 5 |
| • Tightening torque .....   | 5 |
| • No-load current .....   | 5 |
| • Wiring diagram .....  | 6 |
| 2. Precautions on disassembly and reassembly of the charger ..... | 6 |

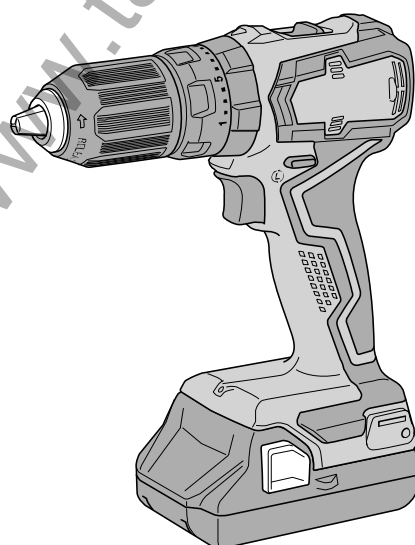

DV 18DD

Koki Holdings Co., Ltd.

Overseas Sales Management Dept.

## REPAIR GUIDE

**WARNING:** Always remove the battery from the main body before starting repair or maintenance work. Because the tool is cordless, inadvertently activating the switch with the battery left in the main body will start the motor rotating unexpectedly, and could cause serious injury.

### 1. Precautions on disassembly and reassembly

**[Bold]** numbers in the description below correspond to the item numbers in the parts lists and exploded assembly diagrams for the Models DV 18DD and DV 18DDX.

## Disassembly

### 1. Removal of the drill chuck

(1) For removal of the Drill Chuck [2] from the drill body, first use a vise to clamp the drill body, and then go to steps (a) and (b) below. A cloth should be placed between the drill body and the vise to protect Housing (A).(B) Set [11] against damage.

(a) Fully open the jaw of the Drill Chuck [2], and then use dedicated driver bit T25 (T-shaped hexalobular screw) to turn the Left-Hand Hexalobular M5 [1] clockwise and remove it.

**NOTE: The Left-Hand Hexalobular M5 [1] is a left-hand threaded screw. Use of a driver bit other than T25 may strip the screw thread and thus prevent the removal of the Drill Chuck [2]. To avoid this situation, be sure to only use dedicated driver bit T25.**

(b) Insert an 8 mm hex. bar wrench into the top of the Drill Chuck [2], clamp it as shown below, and then turn the wrench counterclockwise to detach the chuck. Use a pipe or other means of leverage in case the chuck is difficult to loosen.

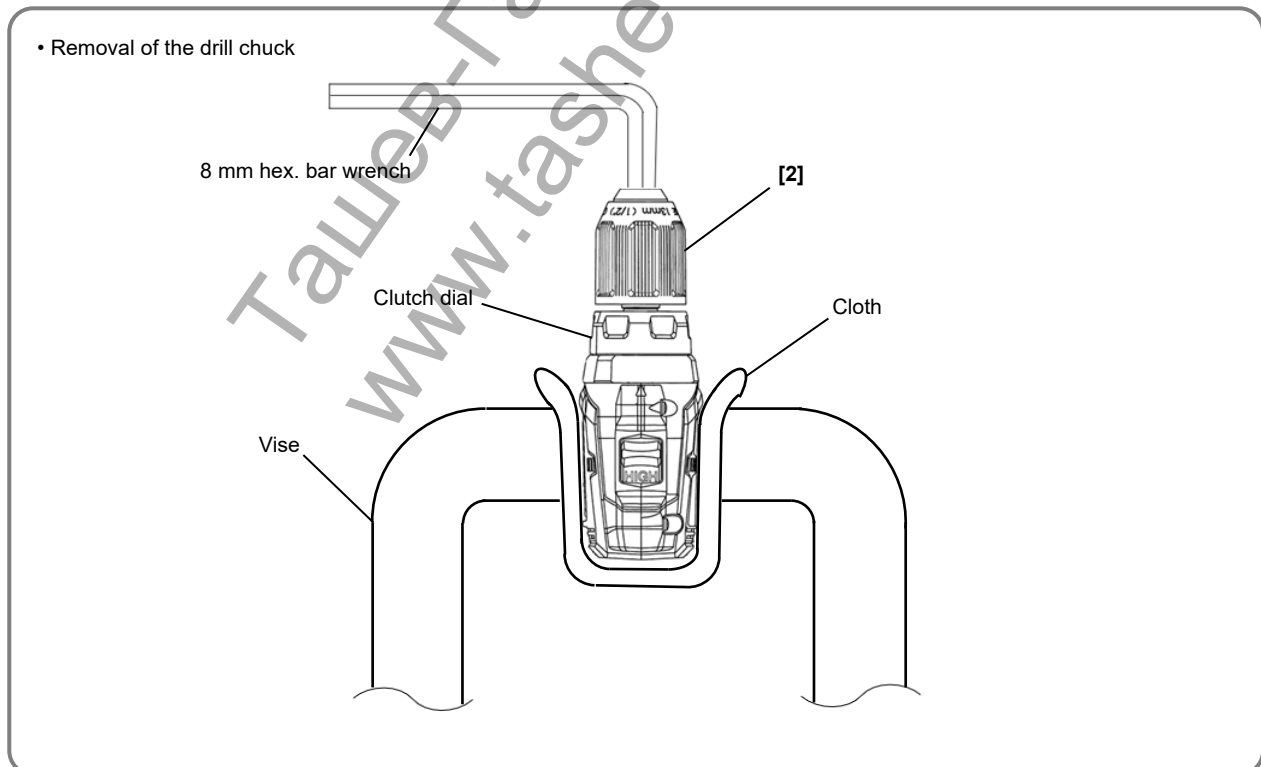

(2) Set the clutch dial to the clutch "1" position.

## 2. Disassembly of housing (A).(B) set

- (1) Remove the eight Tapping Screws (W/Flange) D3 x 16 [4] from the drill body, hold Housing (A).(B) Set [11] at its battery mount portion, and then gently open Housing (A).(B) Set [11].
- (2) Remove housing (B) and remove such built-in parts as modules and units. Lift up Gear Box (C) [3] to remove the built-in parts together from housing (A). The built-in parts are Gear Box (C) [3], Wiring Ass'y [6], Battery Terminal [10], Pushing Button [7], and Shift Knob [9].

• Disassembly of housing (A).(B) set

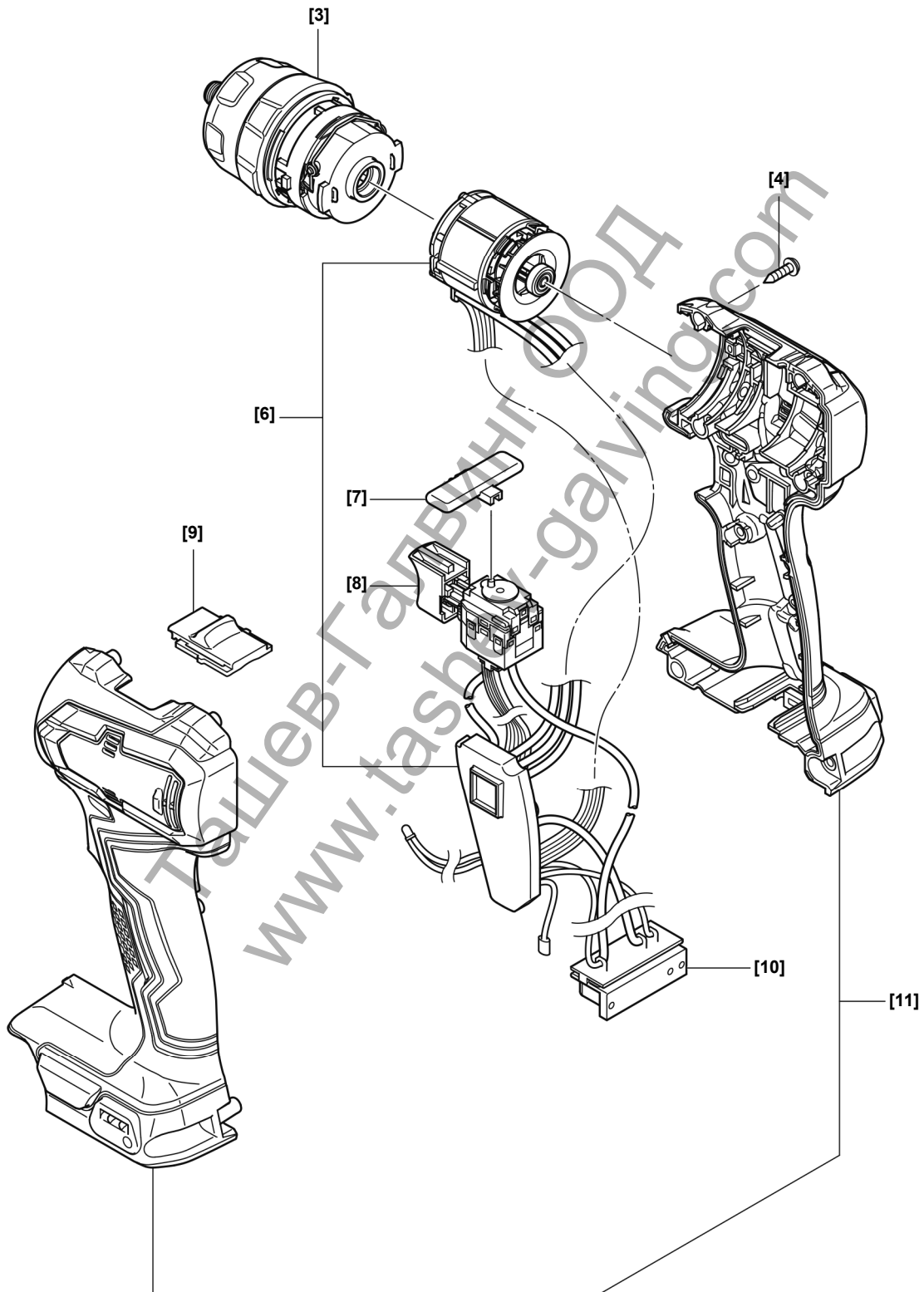

# Reassembly

Generally, perform reassembly by reversing the disassembly procedure. However, special attention should be given to the following items.

## 1. Reassembly of the power supply unit and its vicinity

- Reassembly of the power supply unit and its vicinity

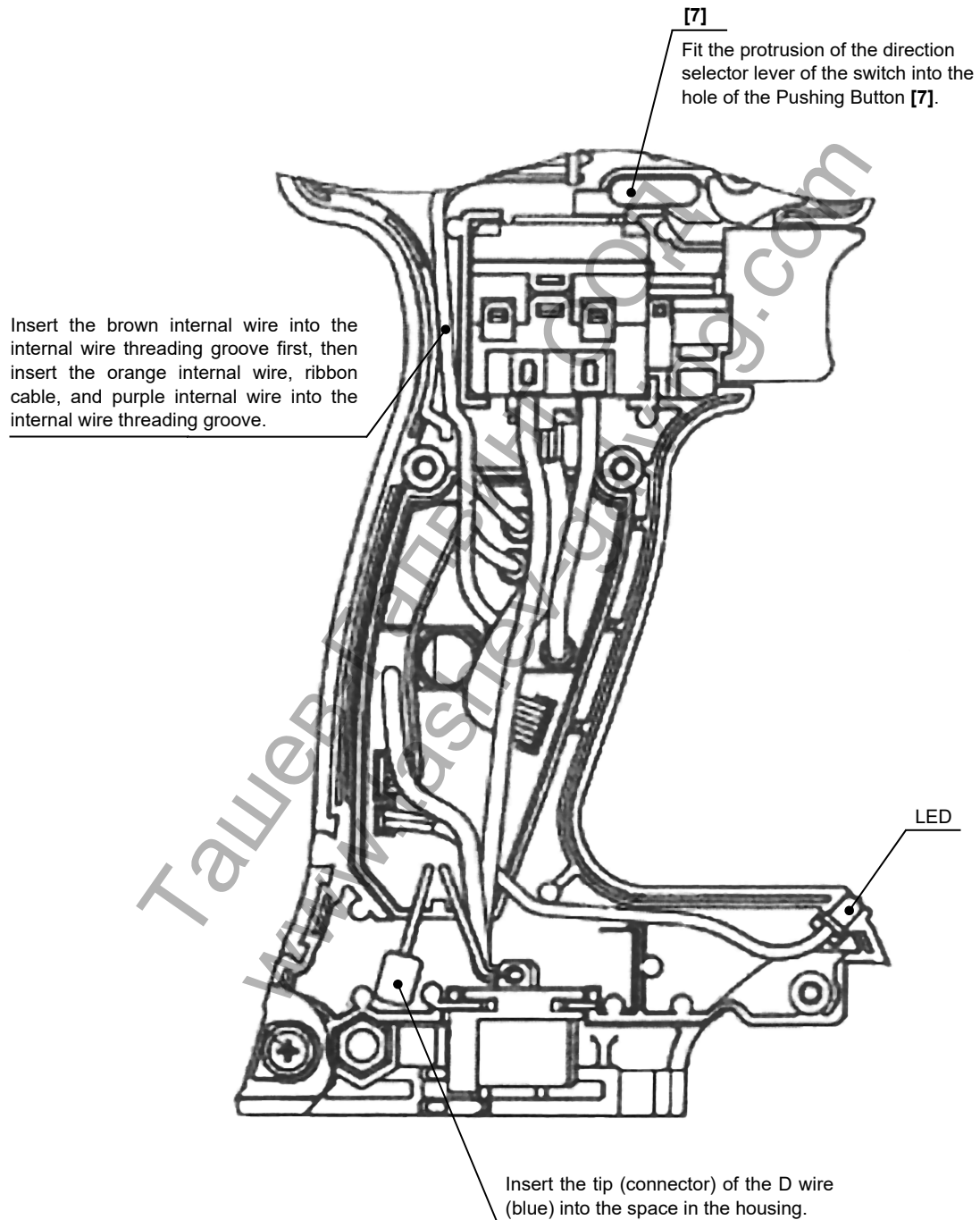

**NOTE: The D wire is intended for exterior communication so that the supplier can check the controller status.**

## 2. Reassembly of housing (A).(B) set

- (1) Mount the reassembled power supply unit and Gear Box (C) [3] in housing (A).
- (2) Check that the protrusion of the direction selector lever of the DC-speed control switch is correctly put in the hole of the Pushing Button [7].
- (3) Mount the shift arm to the groove of the Shift Knob [9] positioning the "HIGH" marking on the Shift Knob [9] at the rear.
- (4) Mount housing (B) to housing (A) and fasten it with the eight Tapping Screws (W/Flange) D3 x 16 [4].
- (5) After completing reassembly up to step (4), check that each marking on the mode-switching dial (screw-tightening mark "⚙️", drill mark "⚙️", and hammer mark "⚔️") is aligned with the triangle mark on Housing (A).(B) Set [11], and the mode-switching dial rotates regularly. Also check that the clutch dial rotates regularly. If the mode is not switched properly or the mode-switching dial or the clutch dial does not rotate regularly, the dial may be improperly mounted. Mount the dial correctly. Check the operation of the Shift Knob [9]. Switch the Shift Knob [9] and make sure the speed is correctly switched between HIGH and LOW. If the speed change is disabled or abnormal, the Shift Knob [9] or other parts may not be properly mounted. Mount the Shift Knob [9] or other parts correctly. Align the mode-switching dial to the hammer mark "⚔️." Pressing the tip of the chuck against a workpiece, pull the trigger switch to check for proper hammering.

## 3. Mounting the drill chuck

- (1) Mount the Drill Chuck [2] to the spindle and fasten it with the Left-Hand Hexalobular M5 [1].

**NOTE:** The tightening torque of the Drill Chuck [2] is  $29.4 \pm 2 \text{ N}\cdot\text{m}$  { $300 \pm 20 \text{ kgf}\cdot\text{cm}$ }. It is higher than that of the conventional models. Securely tighten the Drill Chuck [2] at  $29.4 \pm 2 \text{ N}\cdot\text{m}$  { $300 \pm 20 \text{ kgf}\cdot\text{cm}$ }. If the Drill Chuck [2] is tightened at lower torque, the Drill Chuck [2] may be loose.

## Checking after reassembly

After reassembly, install the battery in the tool body and check for operation of each component as follows.

(1) Checking for lighting of the LED light

Make sure the LED light turns on while pulling the switch and automatically turns off in about ten seconds when you release your finger from the switch.

(2) Checking for rotating direction of the drill chuck

Press the Pushing Button [7] and check the Drill Chuck [2] rotates as indicated on the button. When you press the “R” side of the Pushing Button [7], the Drill Chuck [2] turns clockwise as viewed from the rear of the tool body.

(3) Checking for runout of the drill chuck

Check that runout of the Drill Chuck [2] is 0.8 mm or less under the following conditions.

Condition 1: Set a 12-mm dia. test bar in the Drill Chuck [2] and measure runout of the Drill Chuck [2] at a position 110 mm away from the tip of the Drill Chuck [2].

Condition 2: Set a 6-mm dia. test bar in the Drill Chuck [2] and measure runout of the Drill Chuck [2] at a position 70 mm away from the tip of the Drill Chuck [2].

## Tightening torque

| Item No. | Part name                                | No. used | Tightening torque |        |
|----------|--|----------|-------------------|--------|
|          |  |          | N•m               | kgf•cm |
| [1]      | Left-Hand Hexalobular M5                 | 1        | 3.4±0.5           | 35±5   |
| [2]      | Drill Chuck 13TLRA-N                     | 1        | 29.4±2            | 300±20 |
| [4]      | Tapping Screw (W/Flange) D3 x 16 (Black) | 8        | 1.3±0.3           | 13±3   |

## No-load current

Measure the no-load current by using a fully charged battery after no-load running for five minutes.

No-load current: 2.0±1.0 A (DC 19.8 V—equivalent to the voltage of a fully charged battery) in High mode

## Wiring diagram

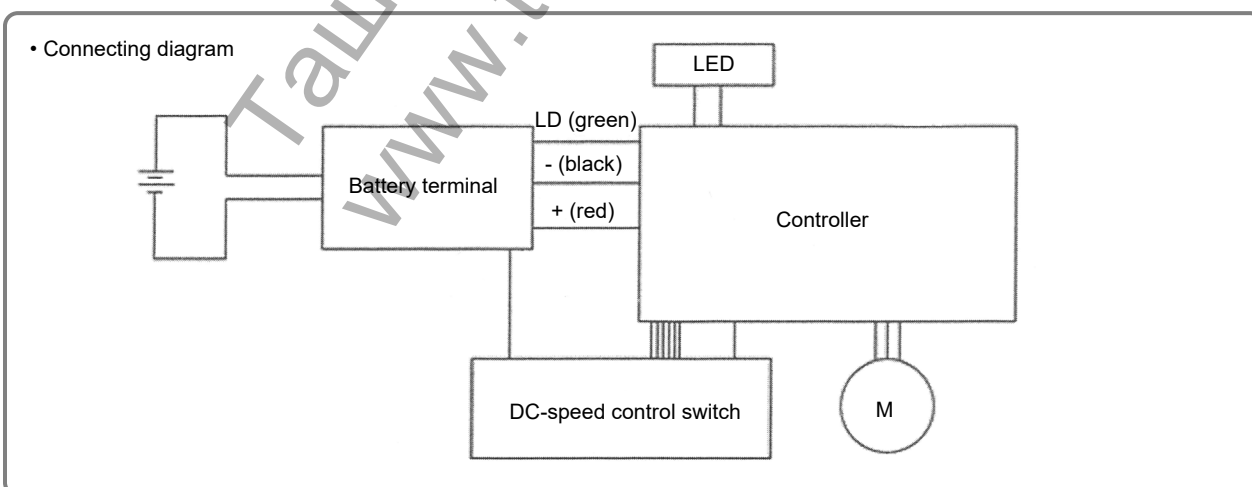
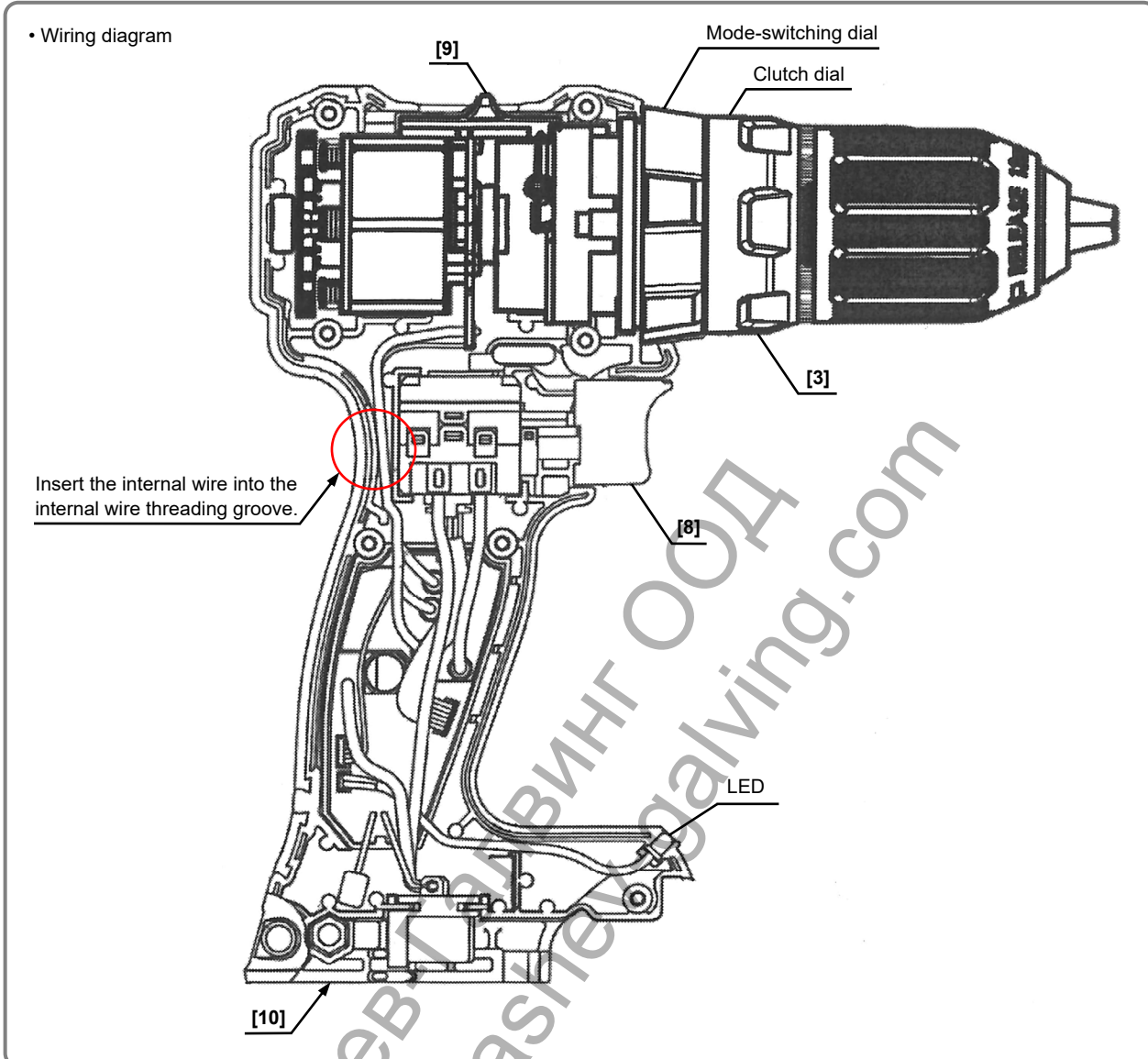

## 2. Precautions on disassembly and reassembly of the charger

Refer to the Service Manual for precautions on disassembly and reassembly of the charger Models UC 18YFSL and UC 18YKSL.

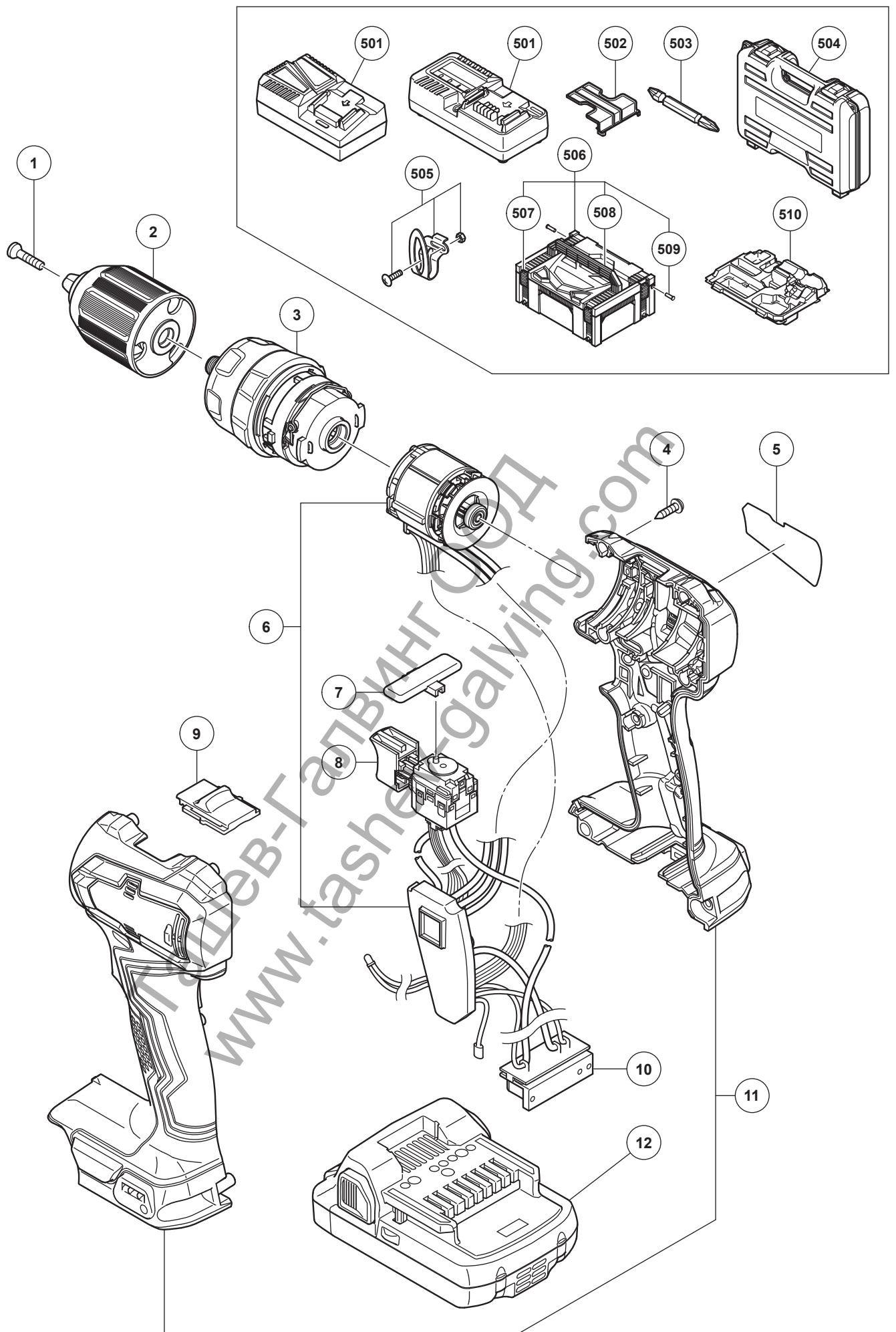

MODEL  
 DV18DD



| ITEM NO.             | CODE NO. | DESCRIPTION                              | NO. USED | REMARKS                     |
|----------------------|----------|--|----------|-----------------------------|
| 1                    | 337426   | LEFT-HAND HEXALOBULAR M5                 | 1        |                             |
| 2                    | 376359   | DRILL CHUCK 13TLRA-N                     | 1        |                             |
| 3                    | 374385   | GEAR BOX (C)                             | 1        |                             |
| 4                    | 313687   | TAPPING SCREW (W/FLANGE) D3 X 16 (BLACK) | 8        |                             |
| 5                    |          | NAME PLATE                               | 1        |                             |
| 6                    | 376360   | WIRING ASS'Y                             | 1        |                             |
| 7                    | 374399   | PUSHING BUTTON                           | 1        |                             |
| 8                    | 376362   | DC-SPEED CONTROL SWITCH                  | 1        |                             |
| 9                    | 374382   | SHIFT KNOB                               | 1        |                             |
| 10                   | 376361   | BATTERY TERMINAL                         | 1        |                             |
| 11                   | 376357   | HOUSING (A).(B) SET                      | 1        |                             |
| *12                  | 333352   | BATTERY BSL 1815 (EUROPE)                | 2        | INCLUD. 502                 |
| *12                  | 334725   | BATTERY BSL 1815 (CHN)                   | 2        | INCLUD. 502                 |
| *12                  | 334726   | BATTERY BSL 1815 (TPE)                   | 2        | INCLUD. 502                 |
| *12                  | 339783   | BATTERY BSL 1830C (EUROPE, AUS, NZL)     | 2        | INCLUD. 502                 |
| *12                  | 376029   | BATTERY BSL 1850C (EUROPE, AUS, NZL)     | 2        | INCLUD. 502                 |
| STANDARD ACCESSORIES |          |  |          |                             |
| *501                 |          | CHARGER (MODEL UC18YKSL)                 | 1        | FOR CHN, SIN, MAL, AUS, NZL |
| *501                 |          | CHARGER (MODEL UC18YFSL)                 | 1        | FOR EUROPE                  |
| 502                  | 329897   | BATTERY COVER                            | 1        |                             |
| 503                  | 983006   | + DRIVER BIT NO. 2 65L                   | 1        |                             |
| 504                  | 336642   | CASE                                     | 1        |                             |
| 505                  | 376358   | HOOK SET                                 | 1        |                             |
| 506                  | 336471   | CASE ASS'Y (STACKABLE 2)                 | 1        | INCLUD. 507-509             |
| 507                  | 336472   | LATCH                                    | 4        |                             |
| 508                  | 336473   | HANDLE                                   | 1        |                             |
| 509                  | 336474   | HINGE                                    | 2        |                             |
| 510                  | 376502   | INNER TRAY                               | 1        |                             |

Ташев-Галвинг  
www.tashev-galving.com